

# Adaptor-Flange Connection for Hågglunds Motors

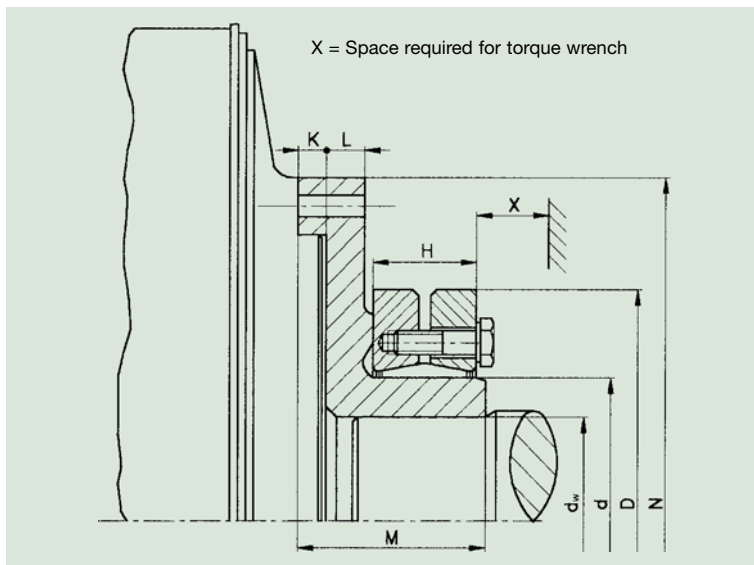

## Flange dimensions

Hågglunds-Motor Series	Adapter Flange Type	dw mm	d mm	N mm	M mm	K mm	L mm	D mm	H mm	X mm	Flange Bolts	Ma Nm	G kg
12	HSDA-12	70-80	100	251	80	15.5	18.5	170	44	26	6 x 3/4 UNF x 1 3/4	310	19
21	HSDA-21	95-115	140	340	100	10	25	230	60	34	12 x 5/8 UNC x 2 1/4	245	32
32	HSDA-32	100-120	155	370	120	31.5	21.5	265	64	34	10 x 3/4 UNF x 3	560	55
43	HSDA-43	125-140	175	400	112	10	25	300	71	34	24 x M 20 x 60	434	54
63	HSDA-63	145-165	200	470	125	10	25	350	86	34	24 x M 20 x 60	434	89
84-1	HSDA-84-1	170-190	240	580	194	24	26	405	144	36	24 x M 24 x 90	750	177
84-2	HSDA-84-2	195-210	260	580	194	24	26	430	120	36	24 x M 24 x 90	750	172

## Shrink Discs

Hågglunds-Motor Series	max. Motor torque Nm	Shrink Disc Type	dw mm	Transmissible torque of Shrink Disc Nm	Bolts Grade 10.9	Tightening torque per bolt Nm
12	4800	100-3071	70	6000	12 x M 8	30
			75	7500		
			80	9000		
21	13500	140-3071	95	15100	10 x M 12	100
			100	17600		
			105	22600		
32	19000	155-3071	110	25000	12 x M 12	100
			115	28000		
			120	31000		
43	36750	175-3071	125	40000	8 x M 16	250
			130	44000		
			140	52000		
63	65000	200-3071	145	72000	12 x M 16	250
			150	78000		
			165	96000		
84-1	151500	240-3091	170	156000	15 x M 20	490
			180	179500		
			190	203000		
84-2	151500	260-3071	195	174000	14 x M 20	490
			200	184000		
			210	204000		